

Preliminary Steps:

1. Read all instructions carefully and study diagrams before installing lights.
2. Check with state and local authorities for laws governing usage and proper mounting of auxiliary lamps.
3. Disconnect ground connection from battery (marked "-") to avoid accidental short circuits before attempting to connect electrical wires.
4. Route new wires along existing wiring. Tape as necessary to correct slack.
5. When running wires through the firewall, keep them away from moving parts.

Mounting Lights:

1. Drill 10.5mm holes for screw placement on the surface where you would like to fix the light.
2. Use the bolt to fasten the lamp, add the locking washer and tighten the bolt.
3. Wiring:
 - Black: Driving / Park light "-"
 - Red: Driving light "+"
 - White: Park Light "+"(White Color)
 - Yellow: Park Light "+"(Amber Color)

Note:

1. E-mark does not apply when using amber park light!
2. Wire color and function is the same on both the light and DT adapter

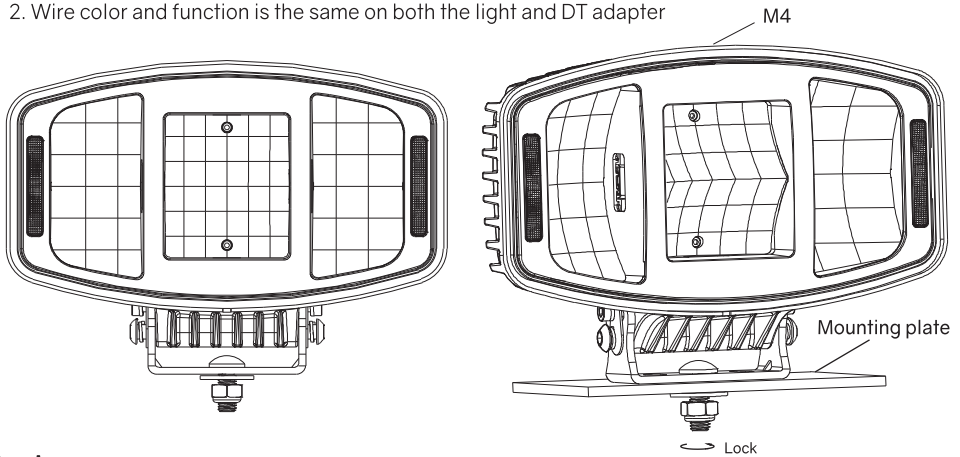

Warning:

1. Works under the specified voltage (DC9-36V).
2. This light becomes hot under continuous use. Don't remove or touch the casing for at least 30 minutes after turning the lamp off.
3. Keep heat-sink clean and exposed to maintain air flow.